

# Memory Stick® Connectors

## CB1 Series

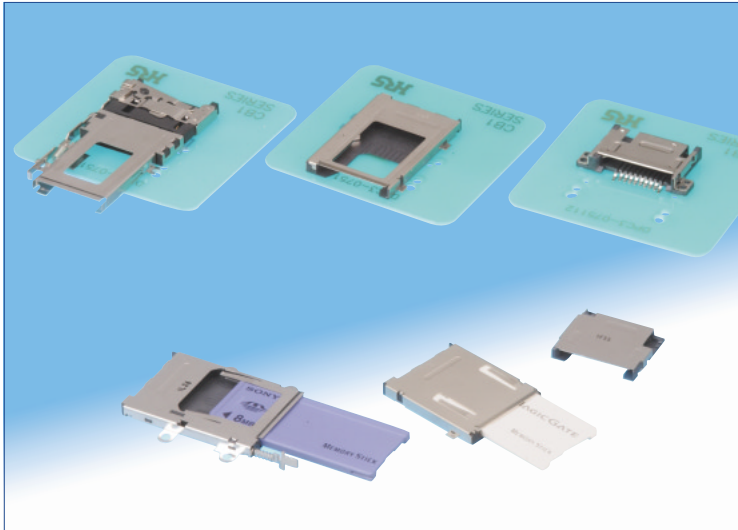

### Card Push Insert/Push Eject <CB1G Series>

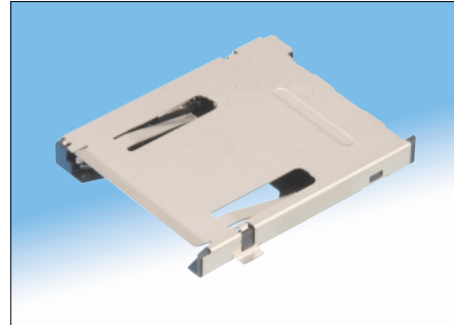

- Card ejection distance of 10 mm
- Mounting height of 3.5 mm
- Mounting area: Smaller design is 78% of former size

### Outline

Receptacle connectors for use with the new generation of digital media devices requiring “Memory Stick®” type of consumer removable memory card.

Several variations are available: Miniature, Low Profile and with or without ejection mechanism.

### Features

#### 1. Indication of Incorrect Card Insertion

The connector will not allow the card to be complete inserted from the wrong end or reversed.

The card will stop about 7mm before complete insertion position, visually indicating incorrect insertion.

#### 2. Protection of the Contacts

Incorrect insertion of the card will not damage the contacts. The card can be easily withdrawn and re-inserted correctly.

#### 3. Excellent Card Handling

The type that is equipped with an ejection mechanism provides a long ejection of the card which offers excellent card handling qualities.

\*Memory Stick is a registered trademark of the Sony Corporation.

### Button Touch Ejection <CB1F Series>

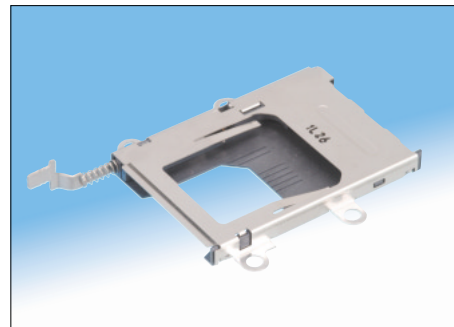

- Card ejection with tactile button operation
- Card ejection distance of 10 mm
- Equipped with card ejection switch

### Without Card Ejection <CB1D Series>



- Miniaturized, low profile design
- Improved installation to the equipment is permitted using (M1.7) tapping screws
- Can be equipped with an ejection mechanism depending on the design of the equipment side portion

Note: Please position the card ejection button at the side of the equipment.

## Product Specifications

Rating	Current rating 0.5A	Operating temperature range -20°C to +85°C(Note)	Operating humidity range Relative humidity 96% max. (No condensation)
	Voltage rating 125V AC	Storage temperature range -40°C to +85°C	

Item	Specification	Conditions
1. Insulation resistance	1000 M ohms min.	500 V DC
2. Withstanding voltage	No flashover or insulation breakdown	500 V AC / one minute
3. Contact resistance	100 m ohms max.	100mA DC
4. Vibration	No electrical discontinuity of 1 μs or more	Frequency: 10 to 55 Hz, single amplitude of 0.75 mm, 2 hours / 3 axis
5. Humidity	Contact resistance: 40 m ohms max. from initial value Insulation resistance: 100 M ohms min.	96 hours at temperature of 40°C±2°C and humidity of 90% to 95%
6. Temperature cycle	Contact resistance: 40 m ohms max. from initial value Insulation resistance: 100 M ohms min.	Temperature: -55°C→+5°C to +35°C→+85°C→+5°C to +35°C Duration: 30→5→30→5(Minutes) 5 cycles
7. Durability (mating/unmating)	Contact resistance: 40m ohms max. from initial value	12000 cycles at 400 to 600 cycles per hour
8. Resistance to soldering heat	No deformation of any component. No affect on contacts	Reflow: At the recommended temperature profile Manual soldering: 300°C for 3 seconds

Note :Includes temperature rise caused by current flow.

## Materials

Part	Material	Finish	Remarks
Insulator	Heat resistant glass reinforced therm oplastic compound	Color: Black	UL94V-0
Contacts	Phosphor bronze	Contact area: Gold plated Termination area: Tin-lead plated or tinned copper plated	—
Metal hold down	Phosphor bronze or stainless steel	Contact area: Nickel plating Termination area: Tin-lead plated or tinned copper plated	CB1E,CB1F,CB1G Series is without the termination area.
Cover	Stainless steel or cupper alloy	—	The CB1E Series has termination area with tin-lead plated.
Eject mechanism components	Stainless steel Heat resistant glass reinforced therm oplastic compound	—	UL94V-0

## Ordering information

CB
1
E
-
10
S
-
1.5
H
-
PEJC
-
\*

① Series name : CB	⑥ Contact pitch : 1.5 mm
② Series No. : 1	⑦ Surface mount
③ Ejector type : C E F G D A	⑧ Eject mechanism codes: PEJC : Card Push insert/Push eject EJL : Left button eject EJR : Right button eject
} With eject mechanism } Without eject mechanism	
④ Number of contacts : 10	⑨ Suffix
⑤ Connector type S : Receptacle	

## Low Profile, Push Insert-Push Eject

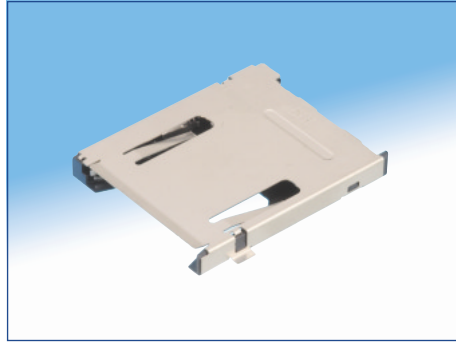

Part No.	CL No.
CB1G-10S-1.5H-PEJC2	CL689-0037-5

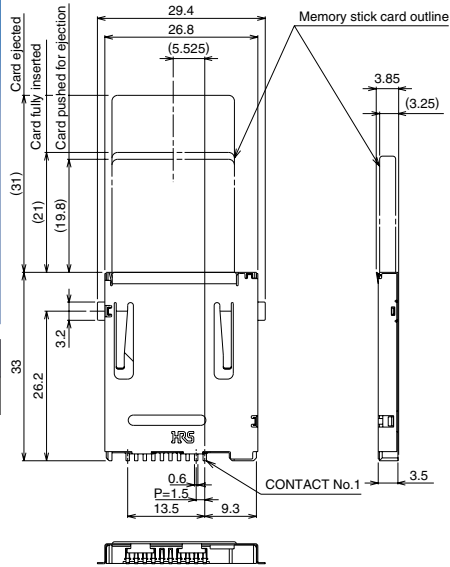

## PCB mounting pattern

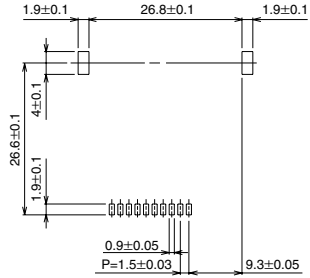

## Button Touch Eject

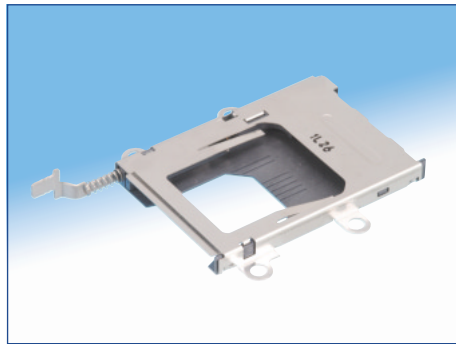

Part No.	CL No.
CB1F-10S-1.5H-TEJL-PA	CL689-0028-4

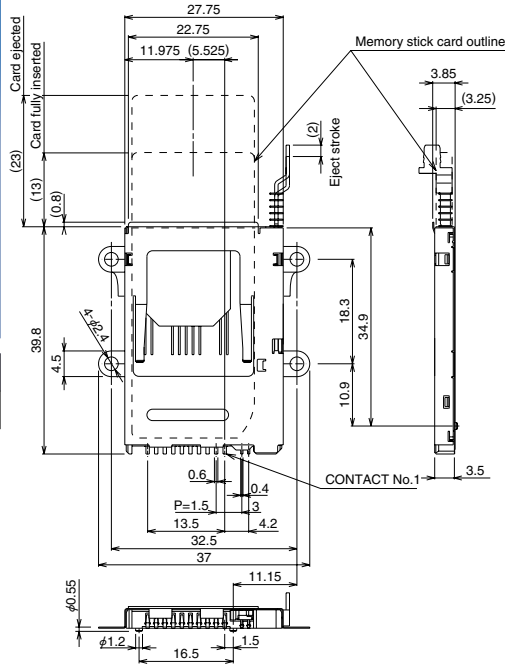

## PCB mounting pattern

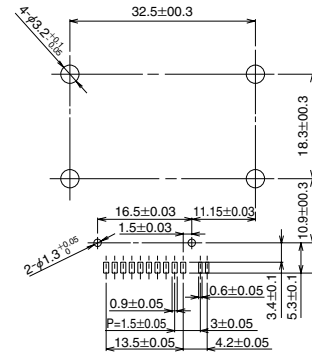

## Without Card Ejection



Part No.	CL No.
CB1D-10S-1.5H	CL689-0021-5

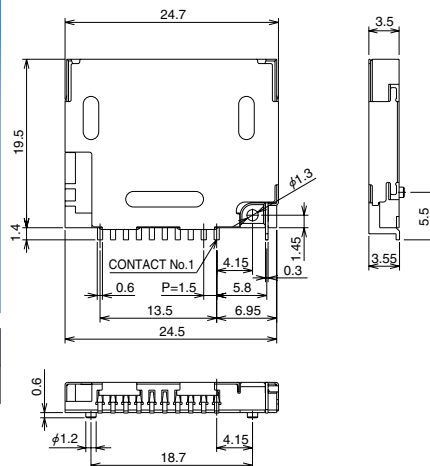

## PCB mounting pattern

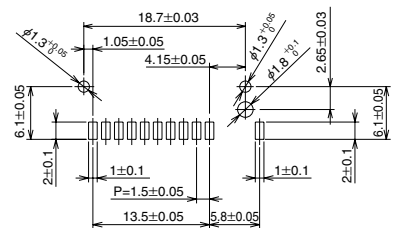

# Push Insert-Push Eject

## ● Normal type

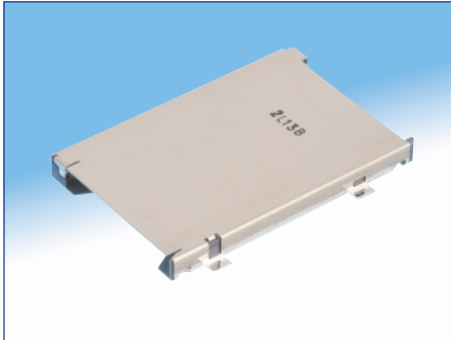

Part No.	CL No.
CB1EB-10S-1.5H-PEJC2	CL689-0026-9

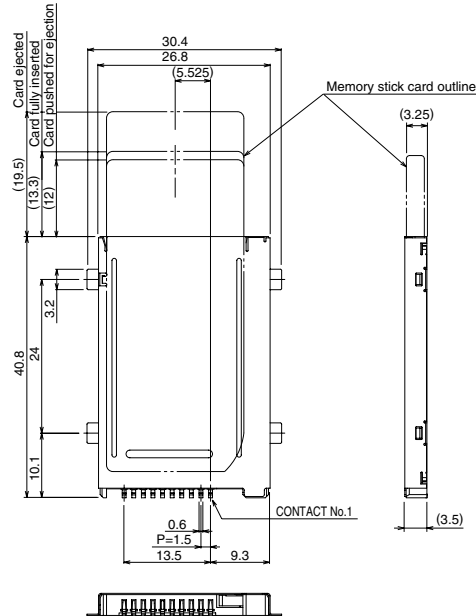

## ◆ PCB mounting pattern

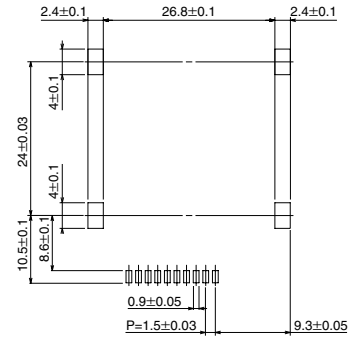

## ● With "U" cut-out

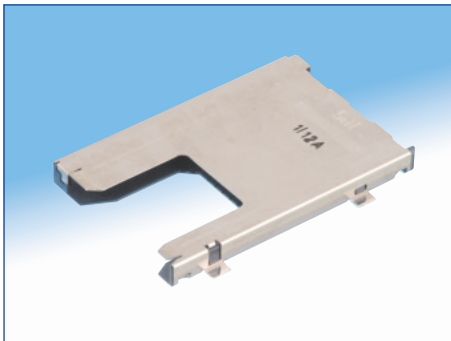

Part No.	CL No.
CB1EBG-10S-1.5H-PEJC2	CL689-0034-7

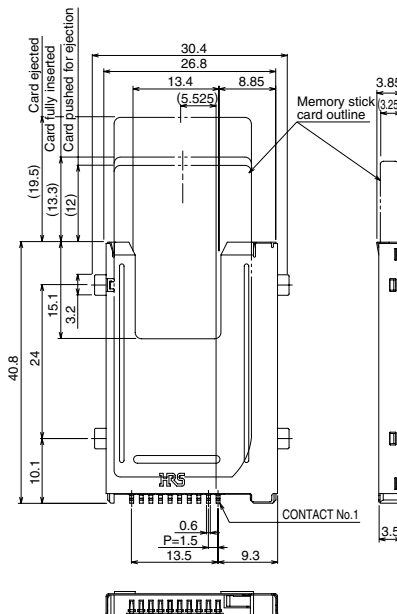

## ◆ PCB mounting pattern

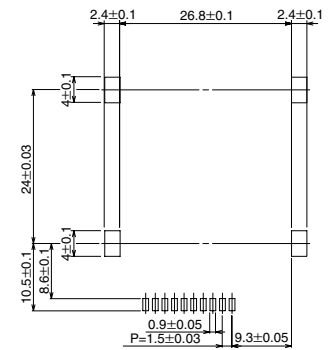

## ● With square window

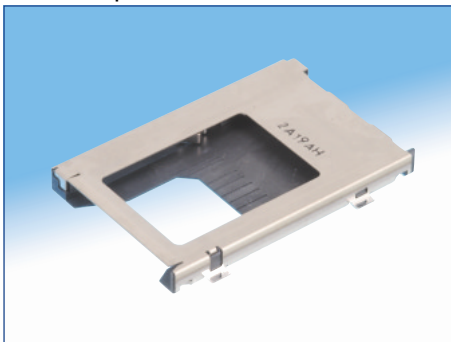

Part No.	CL No.
CB1EBH-10S-1.5H-PEJC2	CL689-0035-0

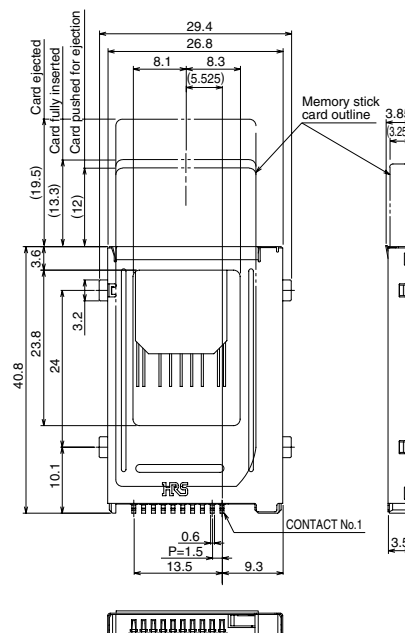

## ◆ PCB mounting pattern

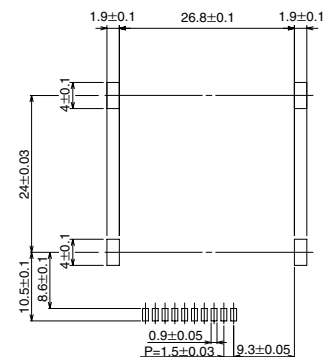

## Left Ejection

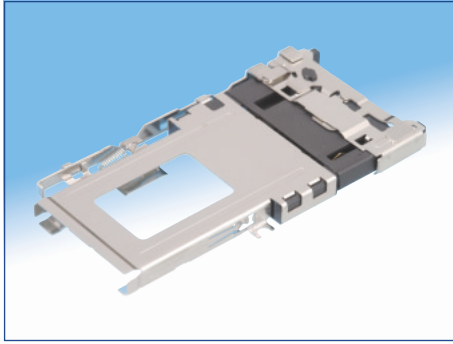

Part No.	CL No.
CB1C-10S-1.5H-EJL(56)	CL689-0006-1-56

### PCB mounting pattern

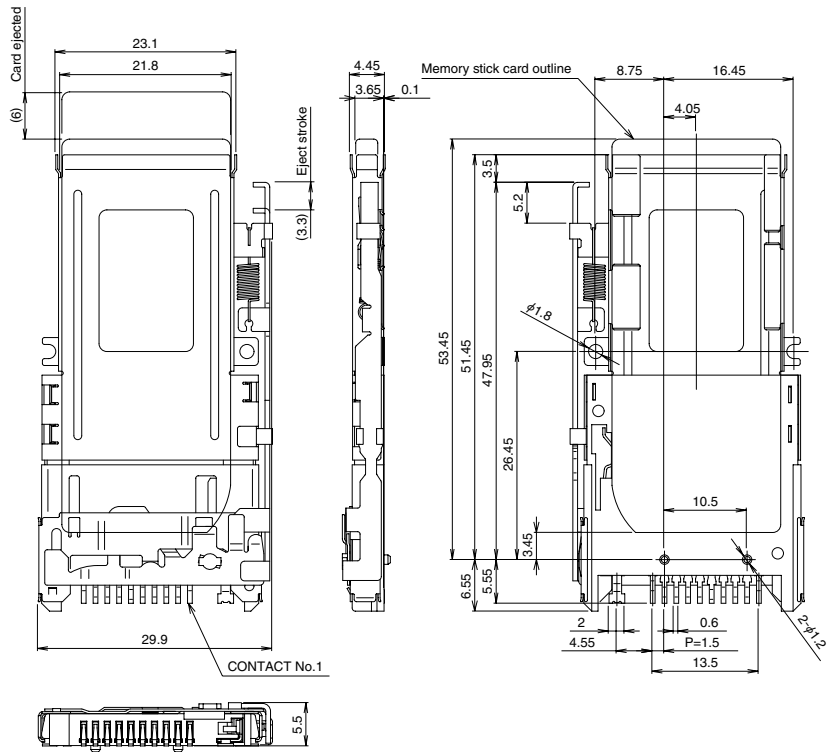
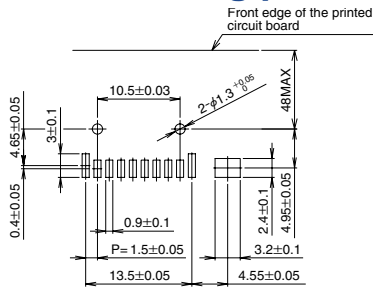

## Right Ejection

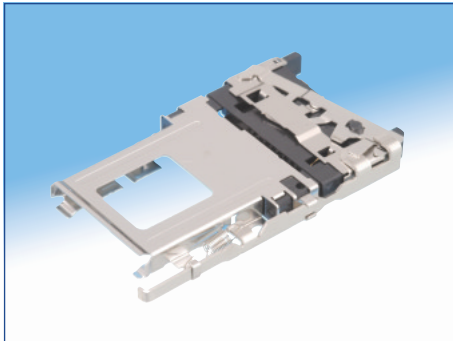

Part No.	CL No.
CB1C-10S-1.5H-EJR(59)	CL689-0007-4-59

### PCB mounting pattern

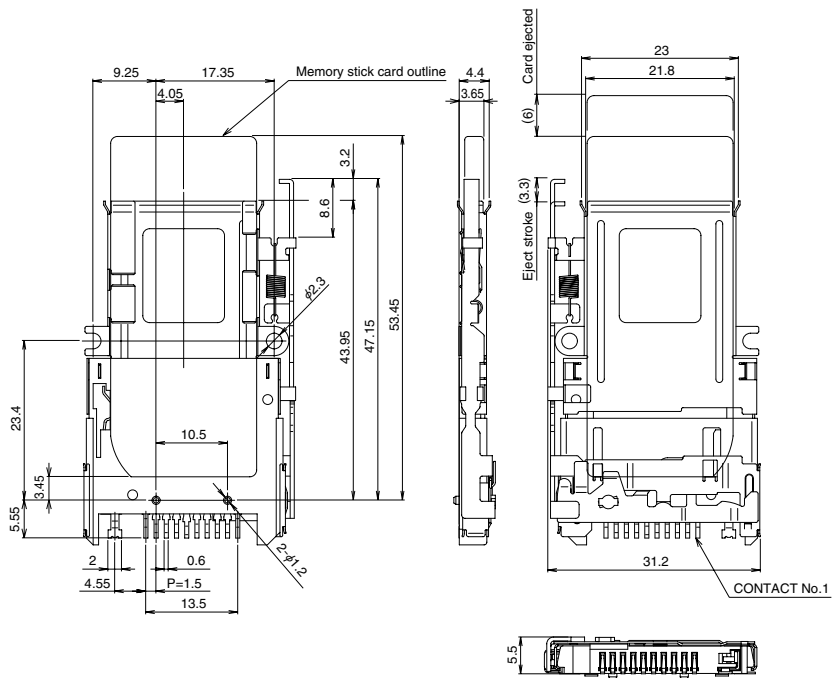
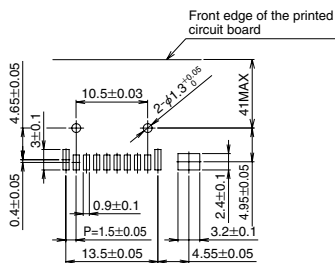

## ■With flange, for screw attachment

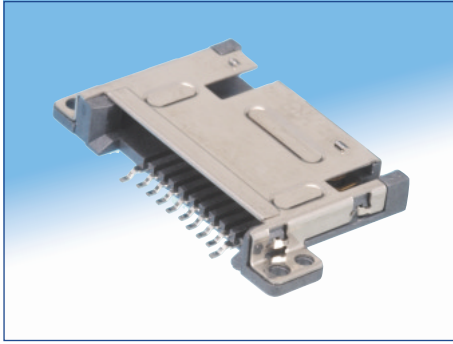

Part No.	CL No.
CB1A-10S-1.5H(57)	CL689-0001-8-57

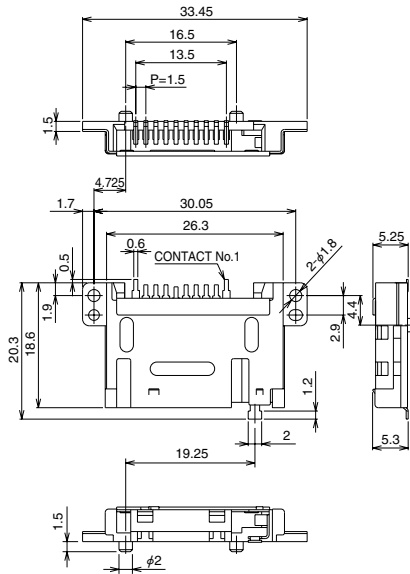

## ◆PCB mounting pattern

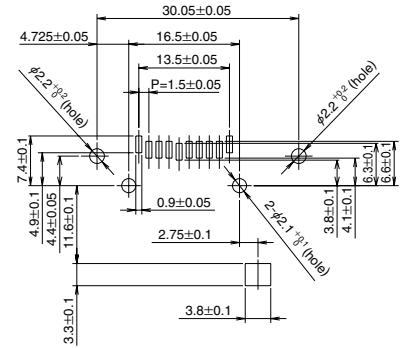

## ■Without flange

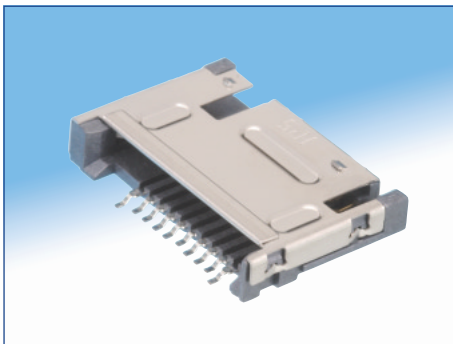

Part No.	CL No.
CB1AA-10S-1.5H(57)	CL689-0002-0-57

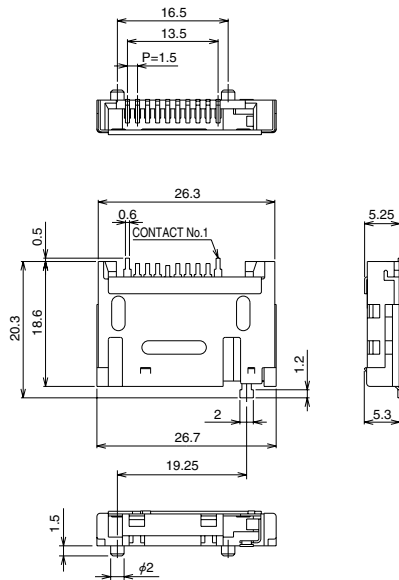

## ◆PCB mounting pattern

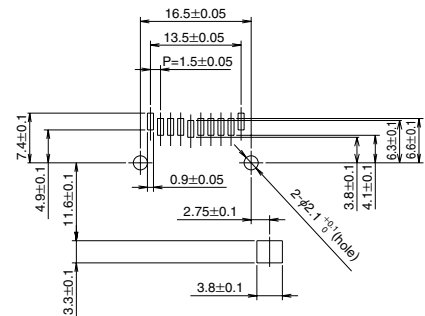

## ◆Memory Stick card insertion direction ◆Memory Stick fully inserted dimensions

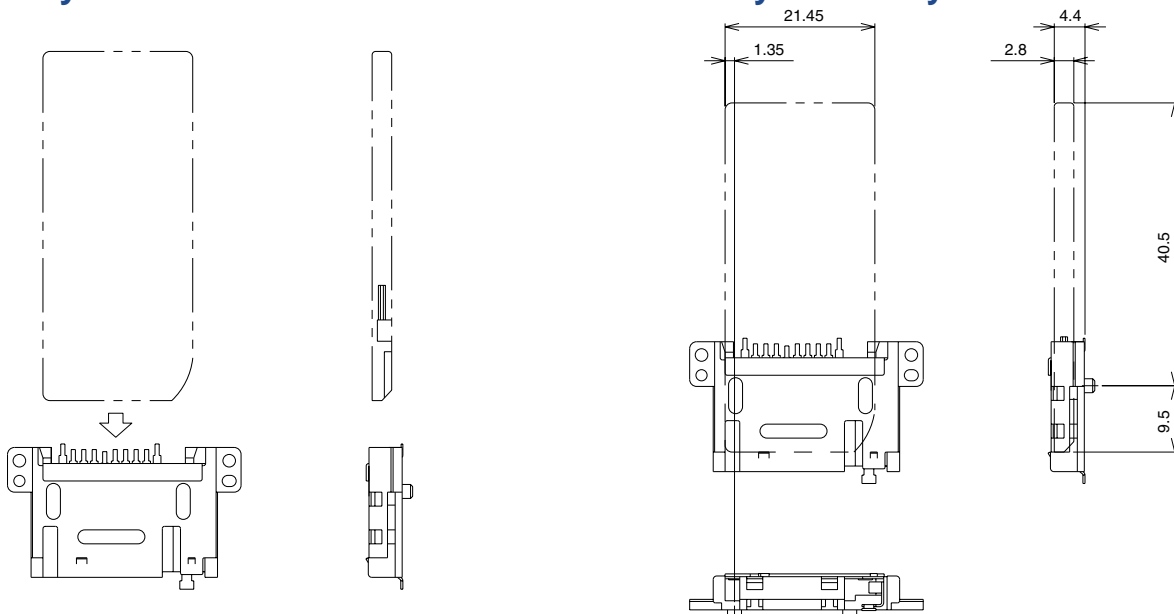

## ■ Packaging specification (Tray packaging)

● Part Number: CB1G-10S-1.5H-PEJC2(1 tray: 40 pieces)

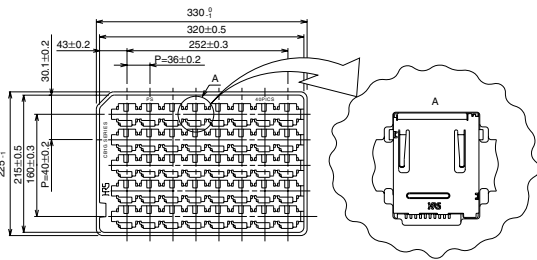

● Part Number: CB1F-10S-1.5H-TEJL-PA(1 tray: 20 pieces)

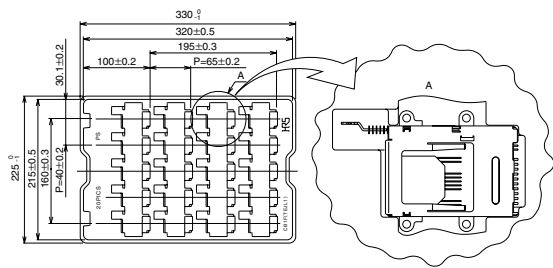

● Part Number: CB1D-10S-1.5H(1 tray: 50 pieces)

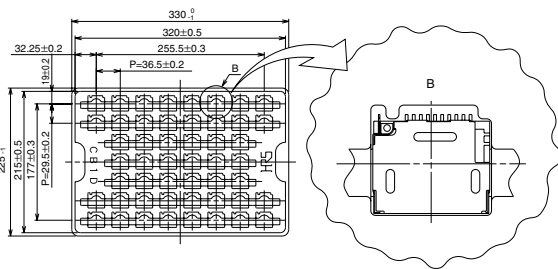

● Part Number: CB1EB\*-10S-1.5H-PEJC2(1 tray: 25 pieces)

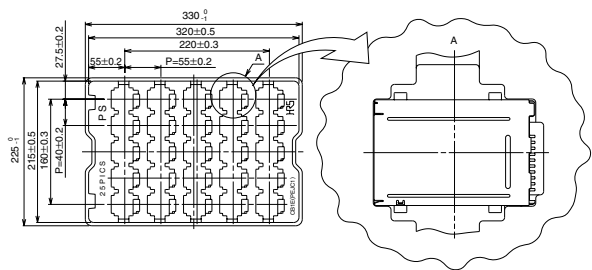

● Part Number: CB1C-10S-1.5H-EJL(56)(1 tray: 20 pieces)

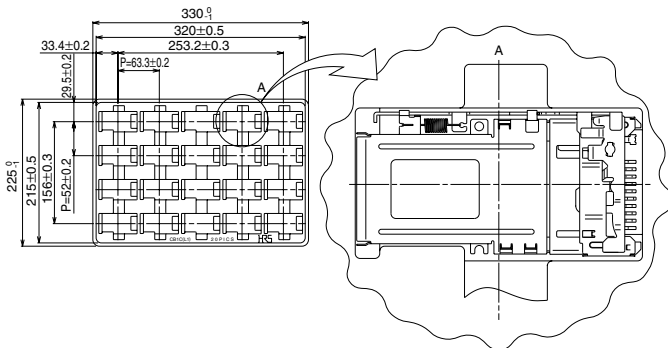

● Part Number: CB1C-10S-1.5H-EJR(59)(1 tray: 20 pieces)

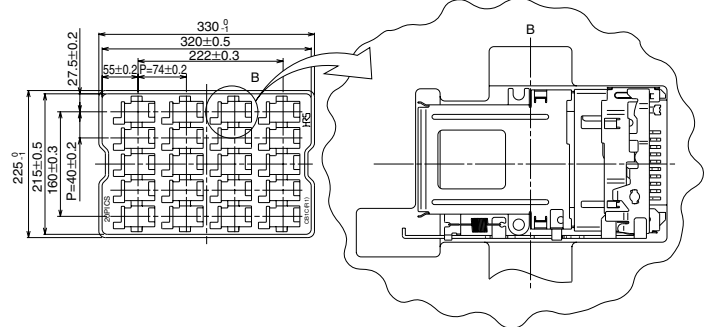

● Part Number: CB1A\*-10S-1.5H(57)(1 tray: 50 pieces)

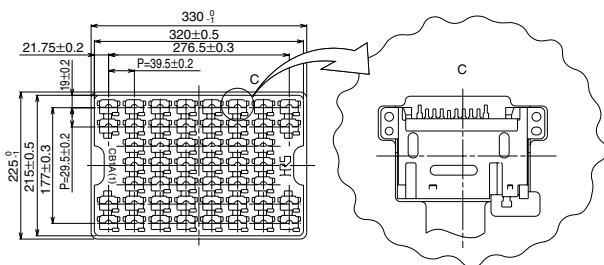

## ◆ Usage Precautions

1. Care should be taken to correctly insert/withdraw the Memory Stick® card. Following correct insertion/withdrawal procedures will prevent device or connector damage.

When handling the CB1C series connectors, hold it in the areas indicated by the arrows, as illustrated below.

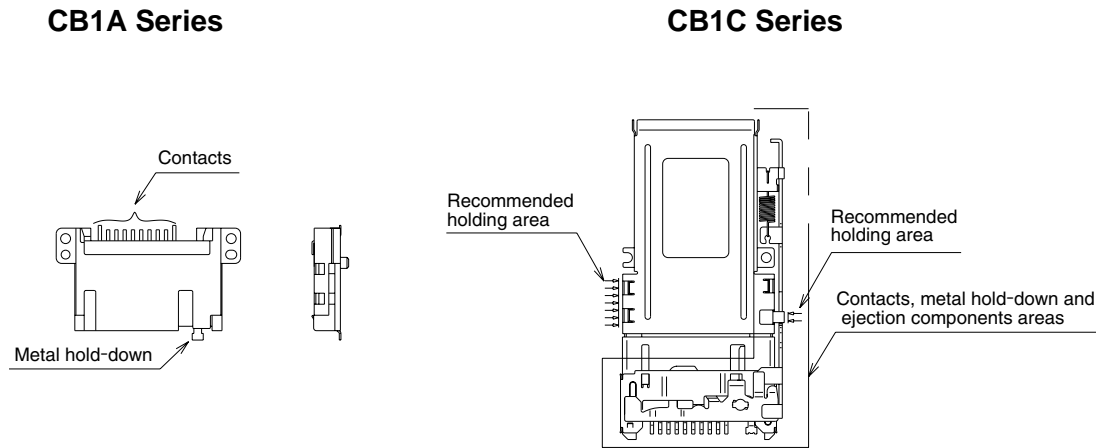

2. Follow the recommended insertion angles, as illustrated below.

<Memory Stick Allowable Insertion Angles>

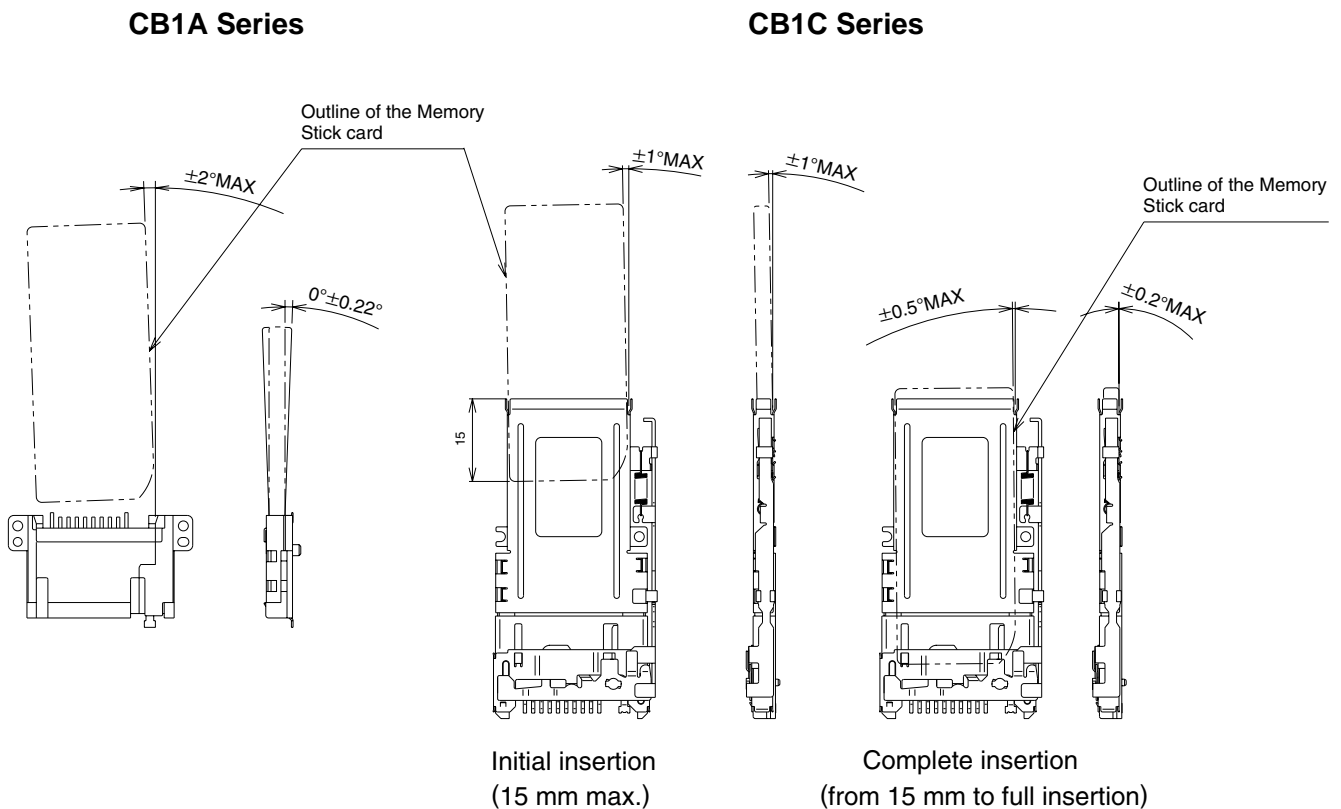



3. When inserting or withdrawing cards from the CB1C Series, the side contacts on both sides will protrude outward by 0.6 mm. Care should be taken that they will not be restricted or touch other components.

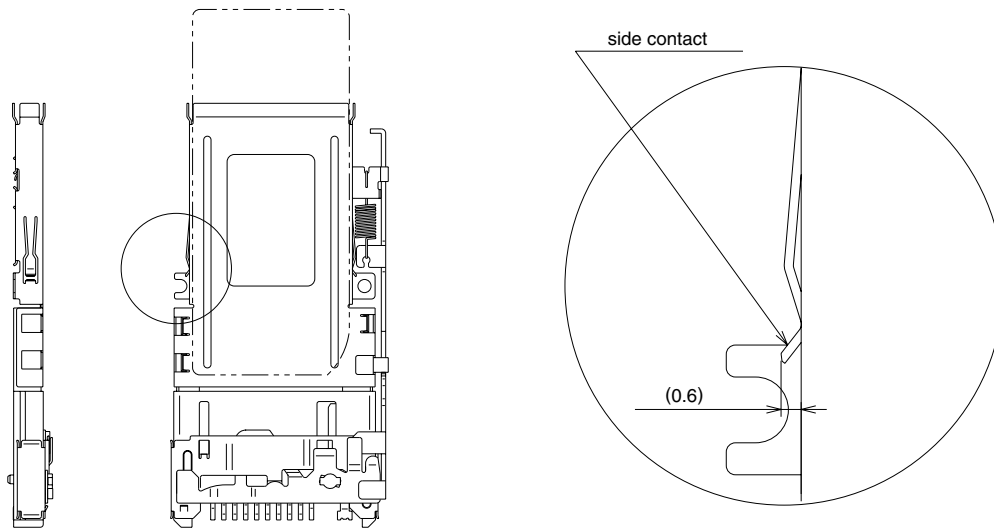

4. Application of an excessive external force to the push rod may prevent the ejection or insertion of the card. Do not apply any load in a direction other than the push direction.

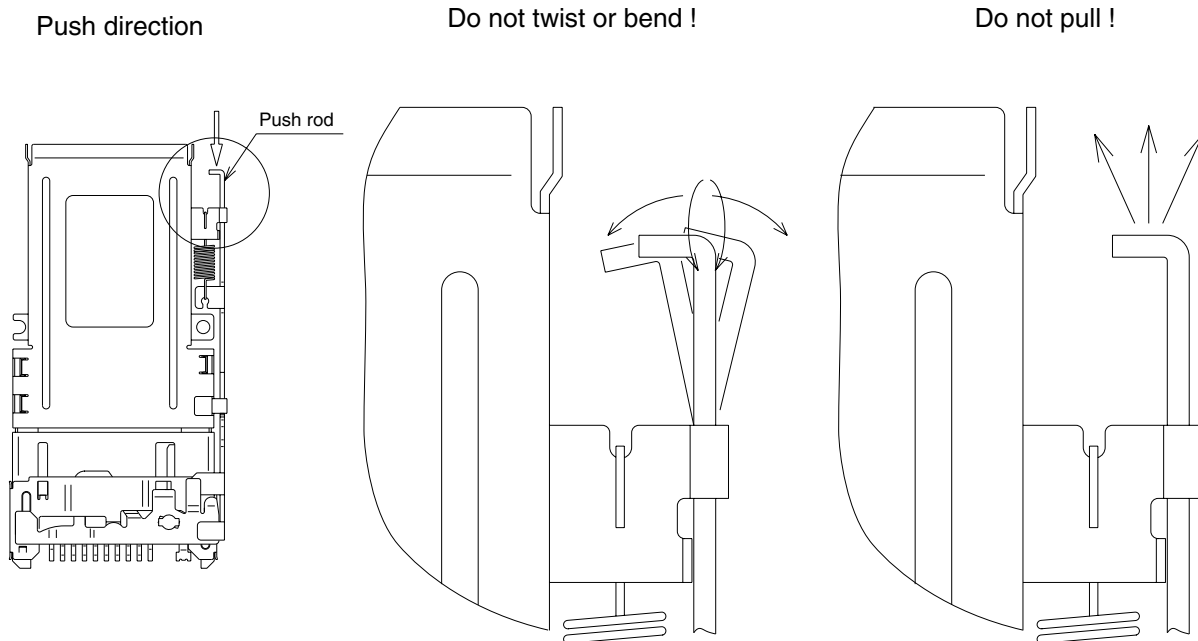

## ■Recommended Temperature Profile

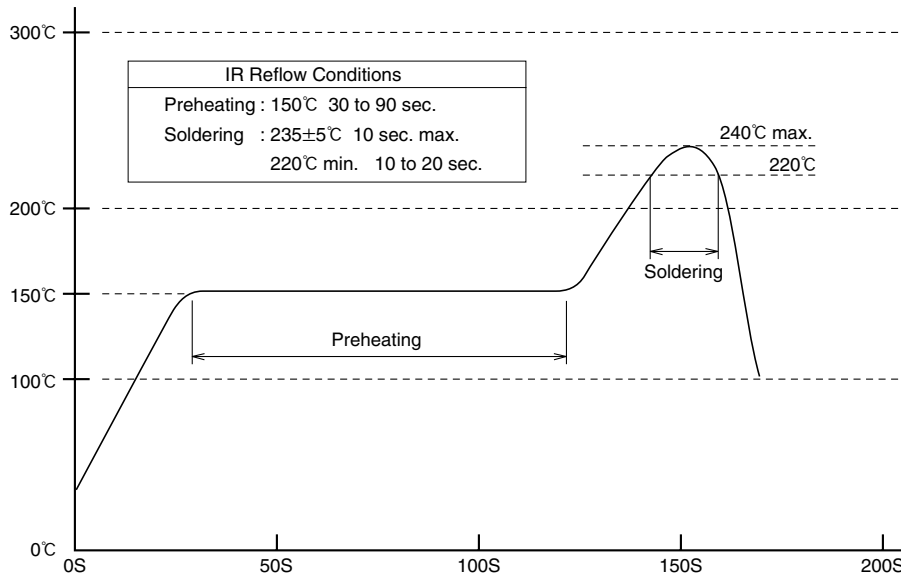

### <Recommended Conditions>

Reflow system : IR reflow

Solder : Paste type 63 Sn/37 Pb (Flux content 9 wt%)

Test board : Glass epoxy 60mm x 100mm x 1.6 mm

Metal mask thickness : 0.15 mm

Recommended temperature.

The temperature may be slightly changed according to the solder paste type and volume used.